

Fuel mixture (2-carburetor-version) 2703

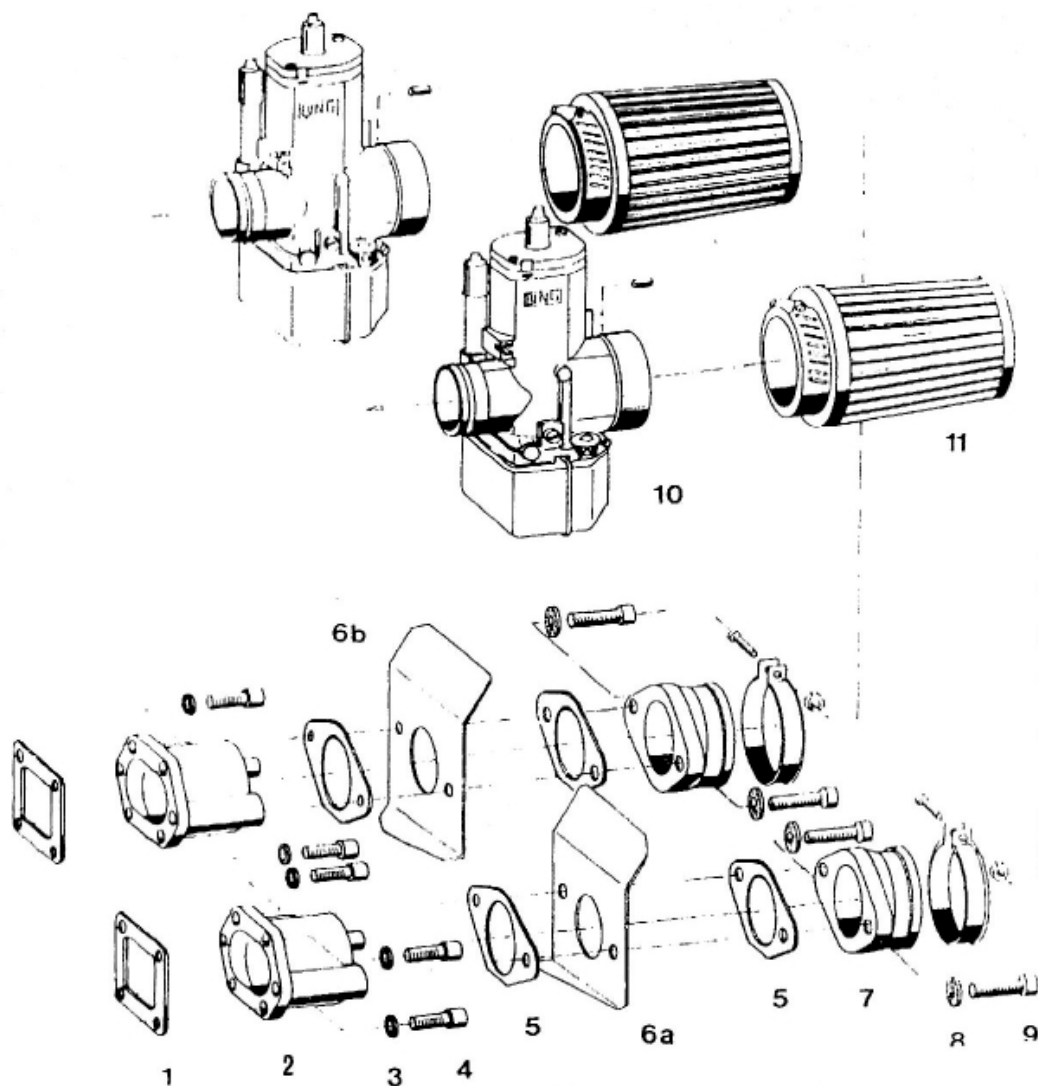

Fig. No.	Quantity	Designation	Part No.	Neoteric Part No	Remark
1	2	Gasket	277 A7		
2	2	Intake manifold	277 G1	6567	
3	8	Serrated lock washer	053.8/6	6902	
4	8	Cylinder screw	DIN 912 M6x20	2292	Md=9,6-11 Nm
5	4	Gasket	277 D7	5454	
6a	1	Heat shield plate, right	277 P11		
6b	1	Heat shield plate, left	277 P10		
7	2	Rubber flange	078.1/3	6567	
8	4	Tab washer	DIN 137 B8,4		
9	4	Cylinder screw	DIN 912 M8x25		Md=23-28 Nm
10	2	BING carburetor	54/38/131	5333	Main Jet: 160, Idle Jet: 45, Needle Jet: 2.72 Jet Needle 6P2 Pos: 1, Air screw: 0,5-1
11	2	Air filter	066.16	6622	